



TOMS OFFROAD

#1917 Ultraflex Fender Flares Installation Instructions

TOOLS NEEDED:

| | |
|-----------------------|---------|
| Drill & Drill Bit Set | Jig Saw |
| Fire Extinguisher | |

PARTS INCLUDED:

| | |
|----------------------------|---------------------------|
| Front & Rear Fender Flares | 100 - Self Tapping Screws |
|----------------------------|---------------------------|

**Read instructions thoroughly prior to installation.
Installing these flares will require cutting of the Bronco sheet metal.**

INSTALLATION:

1. Remove the factory fender and quarter panel support brackets and discard.
2. Starting with the left rear wheel opening, hold the matching flare up to the wheel opening in the location you wish to mount it. The flare should ideally be centered over the wheel. Pay attention to clearance for the fuel caps (these flares DO NOT fit on 1977 Ford Broncos with factory fuel doors).
3. With the flare clamped in place, use a grease marker to outline the shape of the fender flare on the body. (Figure 3) Remove the flare and mark a line 1.5" inward of this line. (Figure 1 & 2) This inward line will be used for the cutting line.
4. Using a jig saw or similar tool, carefully cut along the cutting line (inward line closest to the wheel opening). Use padding between the jig saw and the Bronco body to prevent paint damage.
5. Hold the flare up to the body with the welting pinched between the flare and body. (Figure 4) Using the dimples formed in the flares as a guide, drill the self tapping screws through the flare, welting and body to mount the flare. We recommend starting from the center of the flare and working your way out to the edges. Pay attention to ensure the flare is aligned well with the body lines and that the top of the flare is level.

#1917 Fender Flare Installation Schematics

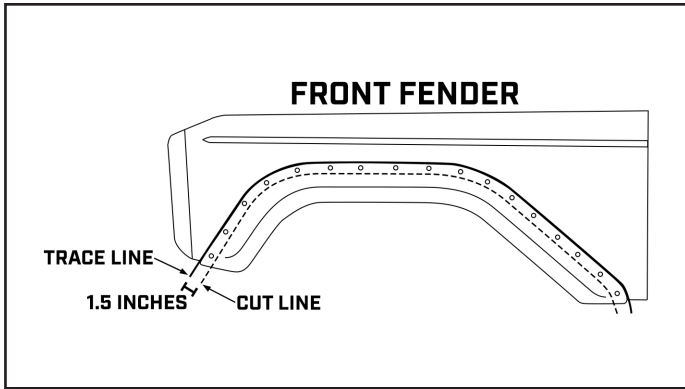

Figure 1

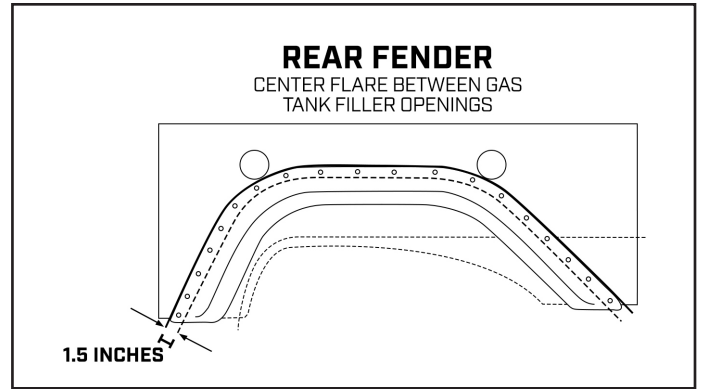

Figure 2

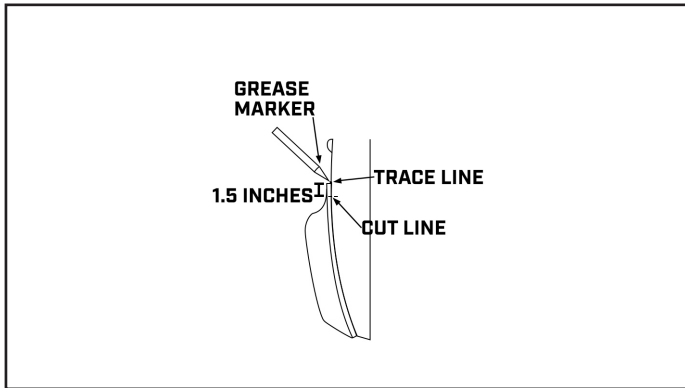

Figure 3

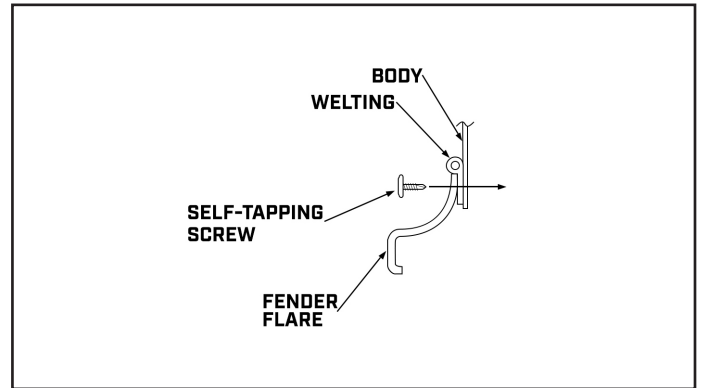

Figure 4