

4

3

2

1

- 1. USE SUPPLIED CAD FOR COMPLETE DEFINITION.
- 2. BREAK ALL EDGES .005".
- 3. REMOVE ALL WELD SPATTER AND NONCONFORMITIES.

REVISIONS				
ZONE	REV.	DESCRIPTION	DATE	APPROVED
	2	initial release	-	JKM
	3	modified for fit & function	7/227/22	JKM
D1, D3	3	3.75 was 3.25	2/13/2024	JKM
	5	20° was 27°, 3° was 10°	3/5/2025	JKM

D

D

C

C

B

B

A

A

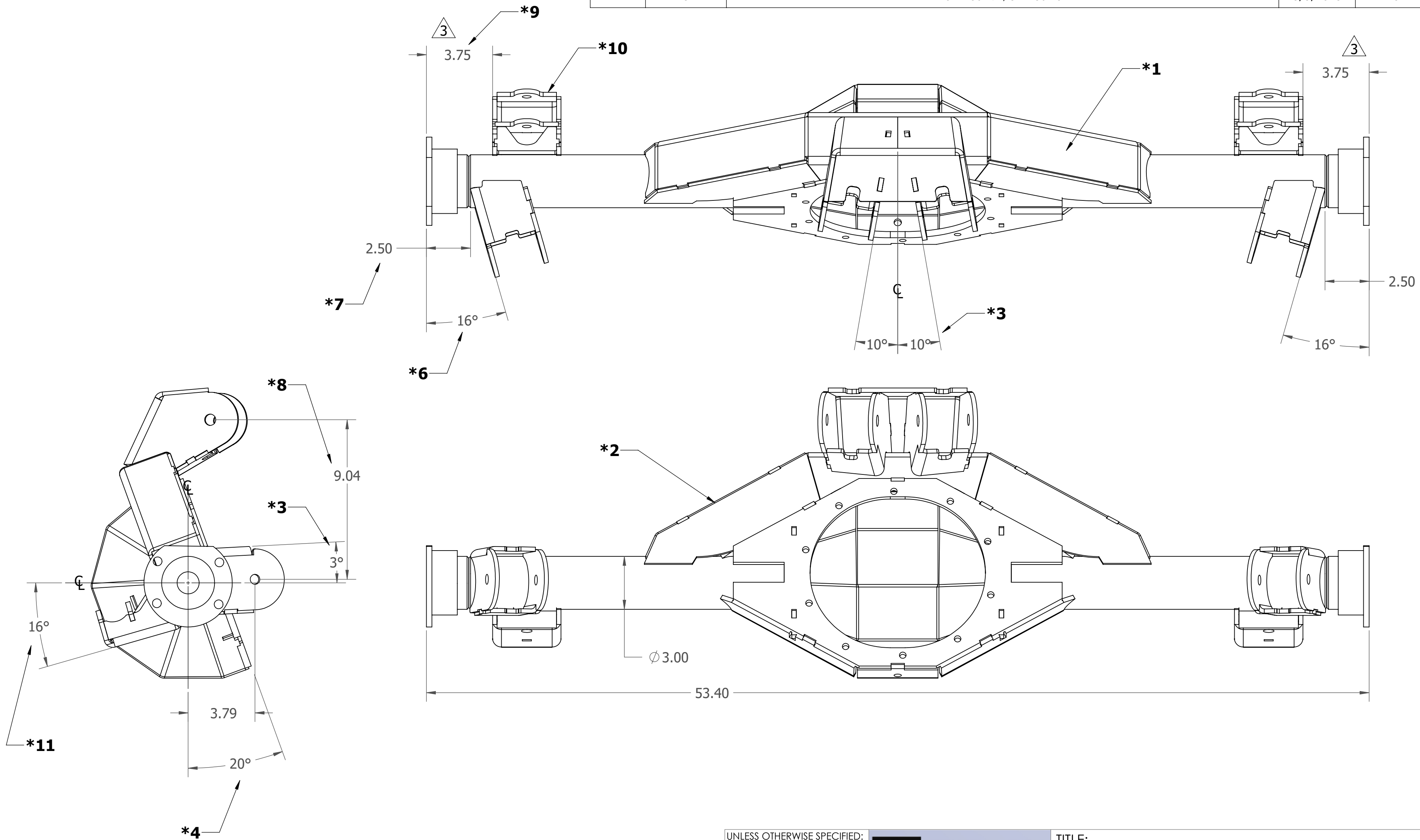

UNLESS OTHERWISE SPECIFIED:  
 DIMENSIONS ARE IN INCHES  
 TOLERANCES:  
 FRACTIONAL ±1/16"  
 ANGULAR: MACH ±.25 BEND ±.5  
 INCH MM

.X	±.040	X	±1
.XX	±.020	.X	±.5
.XXX	±.005	.XX	±.13

MATERIAL -  
 FINISH -



TITLE: Truss & Brkt Asm. for 4-Link Suspension Conversion

PROPRIETARY & CONFIDENTIAL  
 THE INFORMATION CONTAINED IN THIS DRAWING IS THE SOLE PROPERTY OF TOMS OFFROAD. ANY REPRODUCTION IN PART OR AS A WHOLE WITHOUT THE WRITTEN PERMISSION OF TOMS OFFROAD IS PROHIBITED.

NEXT ASSY	USED ON
APPLICATION	DO NOT SCALE DRAWING

DRAWN	NAME	DATE
CHECKED	JKM	2/13/2024
ENG APPR.		
MFG APPR.		
Q.A.		

SIZE	DWG. NO.	REV
C	-	5
SCALE: 1:8	WEIGHT:	SHEET 1 OF 1

4

3

2

1